

THINKDESIGN ENGINEERING

The best solution for 3D Design

think3
Shape a new world.

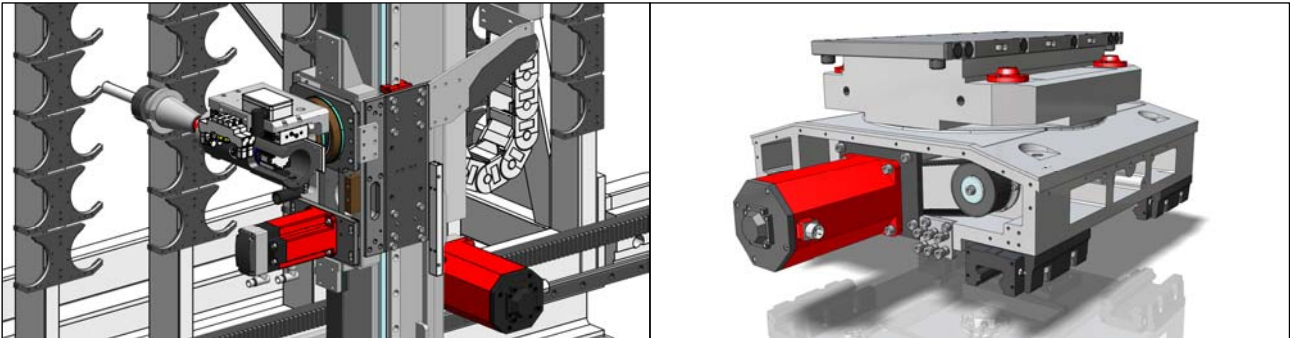

ThinkDesign Engineering addresses the needs of mechanical manufacturing companies by offering productive and reliable tools. From traditional 2D design controls, to innovative and integrated 3D design functionalities in a single environment, ThinkDesign Engineering provides a comprehensive CAD solution that allows companies to define their products in a faster, more efficient and flexible way. Part modeling, 2D/3D transparency, integrated sheet metal functionality, tubing creation and management, advanced assembly management, frame creation, smart objects, animation, data exchange interfaces with other CAD systems, high availability of mechanical parts libraries, direct FEM/FEA interface, product data management, all in one intuitive and easy-to-use product. These are just a few aspects of ThinkDesign Engineering's world. A world created to help manufacturing companies win market challenges.

2D/3D/PLM Transparency

ThinkDesign Engineering's integrated design environment ensures full 2D/3D/PDM transparency and does not require expensive interfaces for the migration from 2D to 3D. ThinkDesign Engineering offers optimized and interoperable 2D and 3D environments that are fully integrated in thinkPLM, think3's PLM (Product Lifecycle Management) application suite. Companies can then preserve and modify existing 2D data, securing their original investment and preventing the risks associated to the migration from one design platform to another.

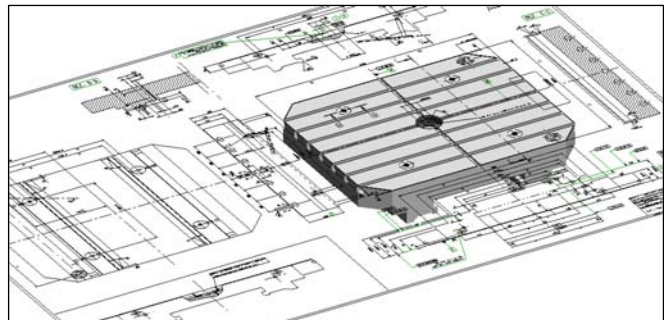

AutoCAD Compatibility

Think3 offers full AutoCAD compatibility: 2D drawings can be imported in ThinkDesign Engineering, modified and reused as native designs. ThinkDesign Engineering combines advanced translation functionality and a modern and comprehensive design architecture. DXF/DWG translators ensure the integrity of AutoCAD entities and support imported data.

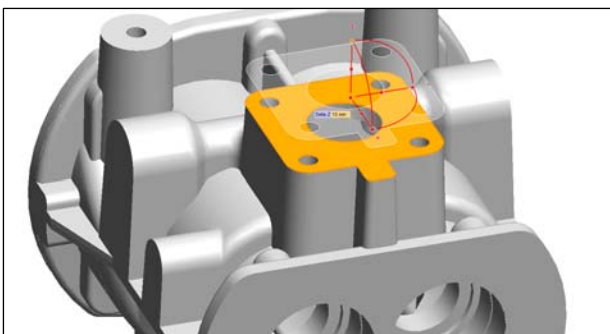

Interactive Solid Modeling

The modern Interactive Solid Modeling feature allows modification of solid geometries, both native and imported, and helps users overcome the parametric logic made of profiles and constraints and the object creation sequence, to get the expected modification result directly. Thanks to its solid modeling and surfacing functionalities, ThinkDesign Engineering ensures innovative part modeling functionalities in a flexible and easy-to-use design environment.

Smart Objects and Adaptive Measures

ThinkDesign Engineering's unique Smart Objects functionality allows the user to capture, reuse and share, either fully or partly, modeling sequences. The benefits are consistency and compliance to company standards, fewer errors and faster design cycles. Adaptive measures allow, when inserting or modifying features, to input dimensional values directly from the surrounding geometry, including solids, surfaces, and static 2D geometric elements, with a simple mouse click. With adaptive measures, users can speed up the modeling process in the context of an assembly, as well as quickly create a 3D model from 2D drawings.

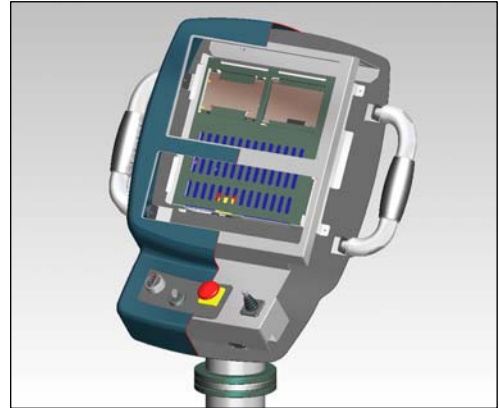

Integrated Sheet Metal

ThinkDesign Engineering's high flexibility allows design engineers to create sheet metal parts more easily, starting from scratch or from existing parts, either native or imported from other CAD systems. ThinkDesign Engineering allows managing thick sheet metal parts with features on side faces while the same model may include parts with different bend tables. In addition, this application allows automatic generation of shop-floor-ready development drawings.

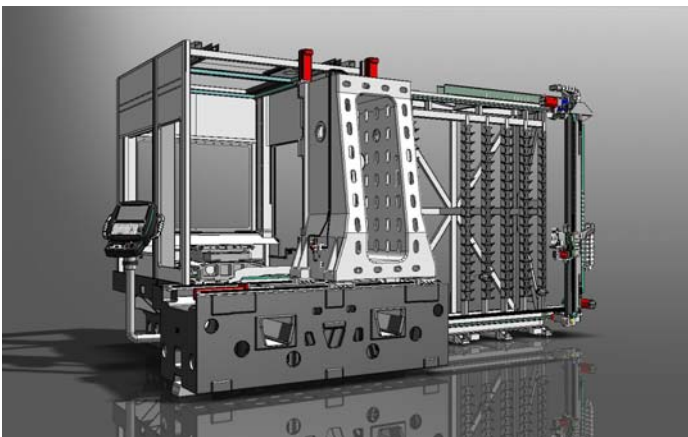

Advanced Assembly Management

ThinkDesign Engineering provides innovative tools for the management of large assemblies and supports both a top-down and bottom-up approach. Simplified representations enable faster loading and viewing, preserving the parametric behavior of the assembly. Visual bookmarks simplify viewing operations and symbolic references allow quick replacement of components or subassemblies. Users can create different configurations of the same machine. The collision detection functionality allows detection of interferences between components and solids of the same assembly.

2D and 3D Translators

ThinkDesign Engineering provides 2D translators for DWG, DXF, IGES and GBG Draftmaker, as well as 3D translators for IGES, STEP, STL, VDA, VRML, WaveFront, IV, ThinkDesign's neutral format and ASCII. Other think3 translation platforms (available separately) support most proprietary 3D formats as well as the two-way conversion of Catia V5, Pro/E and Parasolid files. A two way converter for Catia V4 files is also available (2D included).

System Requirements for ThinkDesign Engineering

Minimum

- Vista™, XP Professional x64 Edition, XP Professional/Home SP2 or higher, Microsoft® Windows® 2000 professional/Server SP4 or higher
- Intel® Pentium 4 2 GHz or equivalent processors supported by SSE2 for AMD systems System memory (RAM) 1 GB, 1.5 GB for Vista™
- Virtual memory (paging) 1 GB
- Disk space 600 MB for a typical installation
- Graphics accelerator 64 MB Vram OpenGL™ 1.4
- Microsoft® .NET Framework Version 2.0 or higher
- Microsoft® Internet Explorer 6.0 SP1 or higher

Suggested

- Vista™, XP Professional x64 Edition, XP Professional/Home SP2 or higher, Microsoft® Windows® 2000 professional/Server SP4 or higher
- Intel® Pentium 4 2.4 GHz or equivalent processors supported by SSE2 for AMD systems
- System memory (RAM) 1.5 GB, 2 GB for Vista™
- Virtual memory (paging) 2 GB
- Disk space 600 MB for a typical installation
- Graphics accelerator 128 MB Vram OpenGL™ 1.4
- Microsoft® .NET Framework Version 2.0 or higher
- Microsoft® Internet Explorer 6.0 SP1 or higher

Mktg 03/2009